

Weight: 10.5 oz for DN, GI, CI or AI pressure types, 16 oz for DI type

Mounting: Panel and DIN rail mounting hardware are standard

Temperature Limits

Operating: -4 to 122°F (-20 to 50°C)

Storage: -40 to 185°F (-40 to 85°C)

Humidity Limits: 5 – 95% RH

Shock: 30 g peak, half-sine, 11ms pulse (tested in accordance with IEC-60068-27)

Vibration: 5 to 2000 Hz, 6.0 g_{rms} (tested in accordance with IEC-60068-27)

Certifications: CE Mark

M1500 Digital Pressure Transmitter User's Manual



The Meriam Process Technologies (Meriam) Model M1500 Digital Pressure Transmitter is a compact, NIST traceable, precision measurement instrument available in a wide variety of pressure ranges and communication / output options. Models are available for differential, gauge, compound and absolute pressure measurements. Output options include analog (4-20mA, 0-5V and two SPST switches) or digital (RS-232, RS-485 or USB) models. Communication with digital M1500's is achieved using Meriam Serial Protocol (MSP), the Meriam DLL or LabVIEW®. Digital units have an option of dual pressure sensors in one unit (any non-differential pressure combination). Personal computer (PC) configuration software is included. The software can be used to configure digital transmitters for use and is required to set up analog transmitter models.

Safety Information











Failure to follow all instructions could result in injury. Read, understand and follow all safety warnings and instructions provided with this product. Also, meet or exceed your employer's safety practices.

In no event shall Meriam be liable for any indirect, special, incidental, consequential or punitive damages or for any lost profits arising out of or relating to any services provided by Meriam or its affiliates. It is not possible for Meriam to identify all foreseeable uses/misuses, therefore all persons involved in commissioning, using or maintaining this product must satisfy themselves that each intended application is acceptable.

Safety Warnings

The table below defines the safety symbols, signal words and corresponding safety messages used in the manual to identify potential hazards and are intended to warn persons about hazards that could result in personal injury or equipment damage.

	This is the Read Instruction Manual symbol. This symbol indicates that you must read the instruction manual.
	This is the Safety Alert symbol. This symbol indicates a WARNING. Warnings alert you to actions that can cause personal injury or pose a physical threat. Please read these carefully.
	This is the Safety Glasses symbol. This symbol indicates that you must wear approved safety glasses during the task.
	This is the Safety Gloves symbol. This symbol indicates that you must wear approved safety gloves during the task.
	Indicates a potentially hazardous situation which, if not avoided, will result in death or serious injury.
	Indicates a potentially hazardous situation which, if not avoided, could result in death or serious injury.
	Indicates a potentially hazardous situation which, if not avoided, could result in minor or moderate injury.
	Indicates information essential for proper product installation, operation or maintenance.

Information in this document is subject to change without notice. Check the Meriam web site (www.meriam.com) for latest manual revision.

RS-485: Half duplex, 3-wire (A, B, GND), 19200 baud (adjustable), 1 start bit, 1 stop bit, no parity. Multidrop addressing with up to 255 devices using Meriam Serial Protocol.

USB: USB 2.0

Analog Outputs

Current: 4–20 mA, 2-wire loop powered or 4-wire systems, minimum loop impedance is 50Ω
 Voltage: 0–5 VDC, 4-wire
 Switches: 2 each, solid state opto-coupler SPST switches
 Rated for 80V DC, 100 mA max.
 For use 4-wire 4–20 mA or 4-wire 0–5 VDC only.

Connections

P1 & P2 Pressure Ports: 1/8" NPT (female)
 Flushing Ports: 5/16 – 24 SAE/MS J1926 (316L SS plugs included)
 Electrical / Communication
 Power: 7 position terminal block (1.3 mm diameter holes suitable for 16 – 25 gauge solid or stranded wire)
 RS-232: DB-9 (female) connector or 7 position terminal block
 RS-485: DB-9 (female) connector or 7 position terminal block
 USB: type B female connector
 Analog: 7 position terminal block (two each), 4 position terminal block & USB mini-B

Power Requirements by Communication / Output Type

RS-232, RS-485: 8 – 36 VDC max., 20 mA min.
 USB: high power (500 mA) USB port or USB hub (PC USB ports and USB hubs with power adapters are typically high power)
 mA, 2-wire: 24 – 36 VDC max. (24 VDC recommended), 60 mA min.
 mA, 4-wire: isolated loop supply of 24 – 36 VDC max., 60 mA min.
 external power supply of 12 – 36 VDC max., 60 mA min.
 V, 4-wire: 12 – 36 VDC max., 60 mA min.

Note: To achieve best accuracy use a power supply(s) with equal or better specifications as the Agilent E3630A:

Ripple & Noise from 20 Hz to 20 MHz
 Normal Mode Voltage rms: 350 μV
 Peak to Peak: 1.5 mV
 Load and Line Regulation:
 0.01% + 2 mV

Enclosure: 4.625" L x 2.125" W x 1.25" H, Aluminum case, 316LSS pressure manifold, IP40 rating

Specifications

NIST Traceable Accuracy

Digital: $\pm 0.025\%$ of FS including all affects of linearity, repeatability, hysteresis and temperature*

Analog: $\pm 0.035\%$ of FS including all affects of linearity, repeatability, hysteresis and temperature*

The DN0010 sensor accuracy is:

Digital: $\pm 0.050\%$ of FS

Analog: $\pm 0.056\%$ of FS

*Temperature Performance: Accuracy statement includes all affects of temperature from -20° to $+50^{\circ}$ C (-4° to $+122^{\circ}$ F)

Update Rate, Single pressure sensor: 14 samples per second

Update Rate, Dual pressure sensors: 7 samples per second

Engineering Units: 32 user selectable units, two user defined units

Pressure Limits

DN sensors: 2x range when pressurized on P1 (HI) side only, 150 PSI when applied simultaneously to P1 (HI) and P2 (LO) sides.

DI sensors: 3x range when pressurized on P1 (HI) side only, 3x range or 150 PSI (whichever is less) on P2 (LO) side only
1000 PSI when applied simultaneously to P1 (HI) and P2 (LO) sides.

GI, CI, AI sensors: 2x range

Zeroing limits

DN, DI, GI and CI sensors: $\pm 5\%$ FS

AI sensors: 100 microns (absolute zero reference)

Media Compatibility

DN sensors: Non-isolated for clean, dry, non-corrosive, non-condensing gases only (Brass, 316L SS, Silicon gel)

DI sensors: Isolated for fluids compatible with 316L SS & Viton[®] (standard)

GI, CI, AI sensors: Isolated for fluids compatible with 316L SS

Digital Communication: Meriam Serial Protocol, DLL or LabVIEW[®]

RS-232: 19200 baud (adj.), 8 data bits, 1 stop bit, no parity.

For customer assistance please call your local Meriam representative or Meriam directly.

Meriam Process Technologies
10920 Madison Avenue
Cleveland, Ohio 44102

Telephone: (216) 281-1100
Fax: (216) 281-0228

E-mail: meriam@meriam.com
Web: www.meriam.com

LabVIEW[®] is a registered trademark of National Instruments

Viton[®] is a registered trademark of DuPont

Table of Contents

Certification/Safety/Warnings	1
Introduction	2
Pressure Sensor Code and Range Table.....	2
CD ROM Resources	3
Meriam Setup Utility.....	3
PC / M1500 Interface.....	3
For Analog Output Configuration	3
For Digital Communication	4
Interface Accessories	4
Mounting Options.....	5
Pressure Connections	6
Single Pressure Sensor Models	7
Dual Pressure Sensor Models	8
Installation and Operation.....	9
M1500 Digital Communication Models.....	9
RS-485	10
USB	10
M1500 Analog Models.....	11
Current Output.....	11
Voltage Output	11
Switch Output.....	12
Wiring Detection Feature	12
Configuration Using Meriam Setup Utility	12
Zeroing the M1500	16
Zeroing Analog M1500s: non-Absolute models	16
Zeroing Analog M1500s: Absolute Pressure Models.....	16
Zeroing Digital M1500s (non-Absolute models).....	17
Zeroing For Mounting Position.....	17
Zeroing DI Models For Static Pressure Effect.....	17
Wiring Diagrams	18
Analog Wiring Diagrams.....	18
Digital Wiring Diagrams.....	20
RS-232 Communication	22
RS-485 Communication	22
USB Communication.....	23

Service and Calibration

In the event an M1500 requires service or needs to be returned for factory recertification or re-calibration, please contact Meriam at the numbers listed below.

DO NOT send any unit in for service without first contacting Meriam for a Return Material Authorization (RMA) number. If this number has not been obtained and clearly marked on the return packaging, the unit will be returned at the shipper's expense. An RMA number will be provided by the Meriam Repair Department when you call, fax or e-mail your information. Certification for Non-Hazardous Materials will also be required. The RMA number must accompany all incoming packages to insure proper tracking, processing and repair work.

To assist us in processing your service request, please have the Model & Serial Number of the unit available when you call. This information is located on the product label.

Meriam Process Technologies

10920 Madison Avenue
Cleveland, Ohio 44102

TELEPHONE: (216) 281-1100

FAX: (216) 281-0228

E-mail: service1@meriam.com

Web Site: www.meriam.com

Over & Under Range Definition Table

Over and under range behavior is defined below for the pressure measurement type (DN, DI, GI, CI and AI) and output type (analog or digital). Consult the table to understand the measurement and output characteristics of a specific M1500 model.

Sensor Output	Hard Under Range	Soft Under Range	Certified Measurement Range	Soft Over Range	Hard Over Range
DN Pressure	< -20% FS ¹	-20 to 0% FS	0 to 100% FS	100 to 120% FS	> 120% FS
Analog	3.5 mA	3.5 to 4 mA	4.0 to 20.0 mA	20 to 22 mA	22 mA
Digital	No value + Status 33,16	Value + Status 32	0 to 100% FS	Value + Status 32	No value + Status 33,17
DI Pressure	< -20% FS ²	-20 to 0% FS	0 to 100% FS	100 to 120% FS	> 120% FS
Analog	3.5 mA	3.5 to 4 mA	4.0 to 20.0 mA	20 to 22 mA	22 mA
Digital	No value + Status 33,16	Value + Status 32	0 to 100% FS	Value + Status 32	No value + Status 33,17
GI Pressure	< -20% FS ³	-20 ³ to 0% FS	0 to 100% FS	100 to 120% FS	> 120% FS
Analog	3.5 mA	3.5 to 4 mA	4.0 to 20.0 mA	20 to 22 mA	22 mA
Digital	No value + Status 33,16	Value + Status 32	0 to 100% FS	Value + Status 32	No value + Status 33,17
CI Pressure	NA ⁴	NA ⁴	0 to 100% FS	100 to 120% FS	> 120% FS
Analog	4 mA @ -14.5 PSIG	4 mA @ -14.5 PSIG	4.0 to 20.0 mA	20 to 22 mA	22 mA
Digital	No value + Status 33,16	No value + Status 33	0 to 100% FS	Value + Status 32	No value + Status 33,17
AI Pressure	NA ⁵	NA ⁵	0 to 100% FS	100 to 120% FS	> 120% FS
Analog	4 mA @ 0 PSIA	4 mA @ 0 PSIA	4.0 to 20.0 mA	20 to 22 mA	22 mA
Digital	No value + Status 33,16	No value + Status 33	0 to 100% FS	Value + Status 32	No value + Status 33,17

Notes:

- ¹ DN units will measure to -20% (or -10 PSID, whichever is greater pressure relative to absolute zero) and +120% of full scale pressure. Calibration certification is for 0 – full scale only.
- ² DI units will measure to -20% (or -150 PSI, whichever is greater pressure relative to absolute zero) and +120% of full scale pressure. Calibration certification is for 0 – full scale only.
- ³ GI units will measure to -20% (or -10 PSIG, whichever is greater pressure relative to absolute zero) and +120% of full scale pressure. Calibration certification is for 0 – full scale only.
- ⁴ CI units will measure to negative barometric pressure (typically -14.7 PSIG) and to +120% of full scale pressure. Calibration certification is for -14.5 PSIG to full scale only.
- ⁵ AI units will measure to +120% of full scale pressure. Calibration certification is for 0 PSIA to full scale only.

- Recertification and Recalibration.....23
- Firmware Refresh.....24
- Firmware Features.....24
- Over & Under Range Definition Table26
- Service and Calibration.....27
- Specifications.....28

Feature / Command Table

Command Type	M1500 models
General configuration commands	
pressure units select	all
pressure sensor exponential damping	all
Special configuration commands	
set network address	RS-485 units only ¹
Get/Set baud rate	RS-232 or RS-485 only
analog output set (URV / LRV)	Analog output units only
tare ² to a specified value	all
tare ² by a specified value	all
remove tare	all
offset ³ to a specified value	all
offset ³ by a specified value	all
remove offset	all
Maintenance commands	
take new pressure zero	all
reset to factory pressure zero	all
field recalibration	all
Process information commands	
primary variable value (sensor 1)	all
primary variable value min / max	all
secondary variable value (sensor 2)	Dual sensor, digital units only ⁴
secondary variable value min / max	Dual sensor, digital units only ⁴
instrument temperature	all
instrument temperature min / max	all
PROD (Precision digits Right of Decimal)	all
AROD (Accurate digits Right of Decimal)	all
LSL (lower sensor limit)	all
USL (upper sensor limit)	all
Product & User information commands	
product information (model & serial no)	all
pressure sensor serial number (assembly sn)	all
pressure module class	all
pressure module type	all
firmware version	all
Description (128 characters)	all
Tag Number (32 characters)	all
Asset Number (32 characters)	all

¹ Network addresses are not necessary for USB units; use USB port address

² Tare is a volatile setting; reset command or cycling power removes tare

³ Offset is a non-volatile setting; rest or cycling power does not remove offset

⁴ The "Get Measure" command returns both pressure values for M1500s with dual sensors when specified

Firmware Reflash

Meriam periodically issues new operating firmware to improve M1500 operation and features. All M1500 units can be reflashed with new firmware using the Meriam Setup Utility.

To install new firmware, save the new firmware file to a known location on a host PC with Internet connection. Follow the "PC / M1500 Interface" instructions in this manual, for analog or digital output versions as appropriate, and connect the M1500 to the host PC. Open the Meriam Setup Utility, set the appropriate Com Port and click on the Reflash Firmware button. Follow the instructions set that appear to reflash the M1500 with the latest firmware version.

Firmware Features

Programming features supported through Meriam Serial Protocol (MSP) and DDL are listed in the table below. See the Meriam Setup Utility or the MSP Implementation Guide for more information on using programming features and information commands.

Certification/Safety/Warnings

⚠ DANGER Fire/Explosion Hazard. This instrument is not intrinsically safe. DO NOT use or service in areas that may contain flammable gas or vapors, combustible dusts or ignitable fibers where an unintended spark can cause a fire/explosion.

⚠ WARNING Do not exceed the Pressure Limits listed in the Specifications section of this manual. Failure to operate within the specified pressure limit could result in death or serious injury.

⚠ CAUTION

- Do not exceed the Maximum Input Voltage listed under "Power Requirements" in the Specification section of this manual
- For Analog output units, do not exceed the Switch Rating listed under "Analog Outputs" in the Specifications section of this manual.
- Disconnect power before servicing.
- Substitution of components may impair operation and safety.
- Do not connect to AC power; use only with DC supply.

Introduction

Congratulations! The M1500 is one of the most capable pressure transmitters available. Follow the instructions in this User's Manual to set up the M1500 to perform to its full potential. Thank you for choosing Meriam.

Pressure Sensor Code and Range Table

Model No. M1500-“Sensor Code with Range”¹ shown below:

Sensor Code ³	Application	Ranges Available
DNxxxx	Differential, Non-isolated	0 – 0010, 0028, 0200, 0415, 2000" H ₂ O
DIxxxx	Differential, Isolated ²	0 – 0001, 0005, 0015, 0030, 0100, 0300, 0500 PSID
GIxxxx	Gauge, Isolated	0 – 0015, 0030, 0050, 0100, 0300, 0500, 1000, 3000 PSIG
CIxxxx	Compound, Isolated	-14.7 to +0015, 0030, 0050, 0100, 0300, 0500, 1000, 3000 PSIG
AIxxxx	Absolute, Isolated	0 – 0017, 0038, 0100, 1000 PSIA

Notes:

¹ Dual Pressure Sensor Units (digital communications option only)

- M1500-“Sensor Code with Range”-“Sensor Code with Range”
- Any combination of GI, CI or AI

² DI Pressure Manifold Options

- 2-port DIxxxx manifolds are standard; use for clean liquid service only
- 4-port DIxxxx flushing manifolds are order options; best for dirty liquids, congealing liquids, and liquids with particulates or suspended solids

³ Media Compatibility

- Non-isolated DN sensors: clean, dry, non-corrosive, non-condensing gases only
- Isolated DI sensors: any media compatible with 316SS & Viton®
- Isolated GI, CI & AI sensors: any media compatible with 316SS

Model Number Examples:

1. ZM1500-DN0415 = M1500, Differential Pressure, Non-isolated, 0 – 415" H₂O
2. ZM1500-DI0030 = M1500, Differential Pressure, Isolated, 0 – 30 PSI
3. ZM1500-GI1000 = M1500, Gauge Pressure, Isolated, 0 – 1000 PSIG
4. ZM1500-CI0100 = M1500, Compound Pressure, Isolated, -14.7 to +100 PSIG
5. ZM1500-AI0017 = M1500, Absolute Pressure, Isolated, 0 – 17 PSIA
6. ZM1500-GI0030-AI0017 = Gauge Pressure, Isolated, 0 – 30 PSIG and Absolute Pressure, Isolated, 0 – 17 PSIA

USB Communication

Connect to the USB type B female connector of the M1500. Use with high power (500 mA) USB ports or powered USB hubs only. The digital interface draws 20mA or less.



Recertification and Recalibration

Meriam recommends annual calibration check and recertification for the M1500. Contact Meriam for this service. Periodic recalibration of M1500 Digital Pressure Transmitters may be necessary to maintain optimum performance. Meriam can also provide this service.

The M1500 does support field recalibration through the Meriam Setup Utility provided on the product CD ROM. Connect the PC to the M1500 according to the “PC / M1500 Interface” and “Installation and Operation” sections of this manual. Install the software as directed by the CD instructions on a suitable PC. Select the Field Recalibration Interface button and follow the directions provided by the software.

Field recalibration should only be executed by qualified personnel using suitable reference standards. These standards should meet the accuracy requirements of your company or industry. Meriam recommends using primary standards at least four times more accurate than the unit under test.

For pressure transmitters up to 200 PSI, Meriam recommends a deadweight tester of at least ±0.0015% of reading for field recalibration. For transmitter ranges of 200 PSI and above, use a deadweight tester of at least ±0.0030% of reading. When calibrating using a dead weight tester referenced to inches of water, be sure the M1500's inches of water reference temperature matches that of the dead weight tester's calibration data.

RS-232 Communication

For RS-232 communication use the terminal block for power and the DB-9 connector for communications. Provide 8-36 VDC power (20 mA minimum) by connecting to the +supply to the **PWR** terminal. Connect the –supply to the **GND** terminal adjacent to **PWR**. For communications connect the receiving device to the M1500's DB-9 (female) serial port (see DB-9 Pin Out Table above) or to the M1500's RX/A and TX/B terminals. Terminal labels follow RS-232 standard TIA/EIA-232. The digital interface draws 20 mA of current or less.

RS-485 Communication

For RS-485 communication use the terminal block for power and the DB-9 connector for communications. Provide 8-36 VDC power (20 mA minimum) in one of two ways: 1) by connecting the +supply to the **PWR** terminal and the –supply to the adjacent **GND** terminal or 2) by connecting the +supply to DB-9 Pin #2 and the –supply to DB-9 Pin #1. For communications connect the receiving device to the M1500's DB-9 (female) serial port (see DB-9 Pin Out Table above) or to the M1500's RX/A and TX/B terminals. The digital interface draws 20 mA of current or less.

CD ROM Resources

Each M1500 comes with a product CD ROM that includes the following resources:

- Meriam Setup Utility
- Meriam Serial Protocol (MSP) Implementation Guide
- USB Drivers
- LabVIEW® Drivers (VIs)

Please make use of these resources as referenced in this manual.

Meriam Setup Utility

The M1500 Meriam Setup Utility runs on Microsoft Windows® XP, Windows® Vista and Windows® 7 operating systems. Place the CD in the PC's CD ROM drive and install the software using the installation utility. The software is used to configure M1500 Digital Transmitters by setting engineering units, damp rate and other parameters, to zero the unit, or to set the output span on analog units. See the "PC Interface" section of this manual for information on connecting the M1500 to a host PC.

The Software user interface provides the following user selections:

- 1.) Startup
- 2.) Measurement and Configuration
- 3.) Set Analog Output
- 4.) Transmitter Information
- 5.) Reflash Firmware
- 6.) Field Recalibration

The Software provides user instruction and / or drop down selection boxes once the desired option is selected. See the Software's HELP feature for more details.

PC / M1500 Interface

For Analog Output Configuration

To configure an M1500 with analog output, connect the unit to a host PC using a USB type A to USB type mini-B cable as shown in the diagram below. The USB connection will power the M1500 and

provide communication for configuration setup when connected to high power (500 mA) USB ports or powered USB hubs. Open the M1500 Meriam Setup Utility application to configure the transmitter as desired. See the “Installation and Operation” section of this manual for additional information.

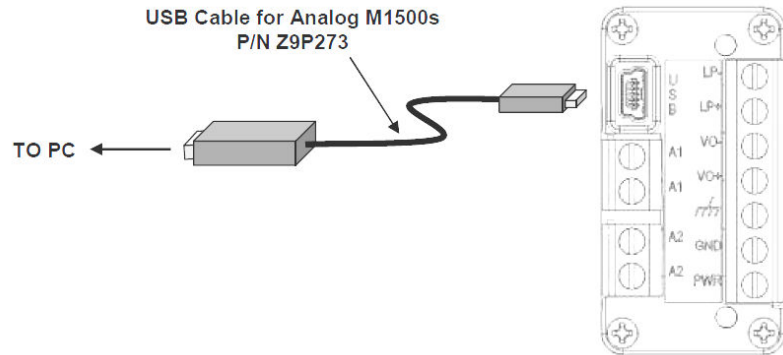

For Digital Communication M1500s

Connect the M1500 to a host PC, using the RS-232, RS-485 or USB connections provided. See the “Digital Wiring Diagrams” section of this manual for more details. Use the M1500 Meriam Setup Utility to configure the transmitter or use MSP commands (see protocol documentation on the product CD or at www.meriam.com under Resources / Application Notes). The M1500 pressure default network address is 40 (0x28 Hex) and module address is 64 (0x40 Hex) for MSP and LabVIEW®. See the “Installation and Operation” section of this manual for additional information.

NOTICE

USB drivers must be installed on the host PC prior to communication with M1500 USB models. Find these drivers on the product CD.

Interface Accessories

The following table lists part numbers for various accessories available to assist in configuration or communication.

Part Number	Description	Accessory Status
Z9A000003PN06	M1500 Product CD ROM	Standard, all models
Z9P273	USB type A to USB type mini-B cable—used with analog output M1500s to interface with PC & configuration software	Optional for analog models, initial set up & support
Z7621-1	RS-232 to RS-485 Converter, PC Mount, port powered	Optional for RS-485 models initial set up & support
Z7621	RS-232 to RS-485 Converter, DIN rail	Optional for RS-485

Digital Wiring Diagrams

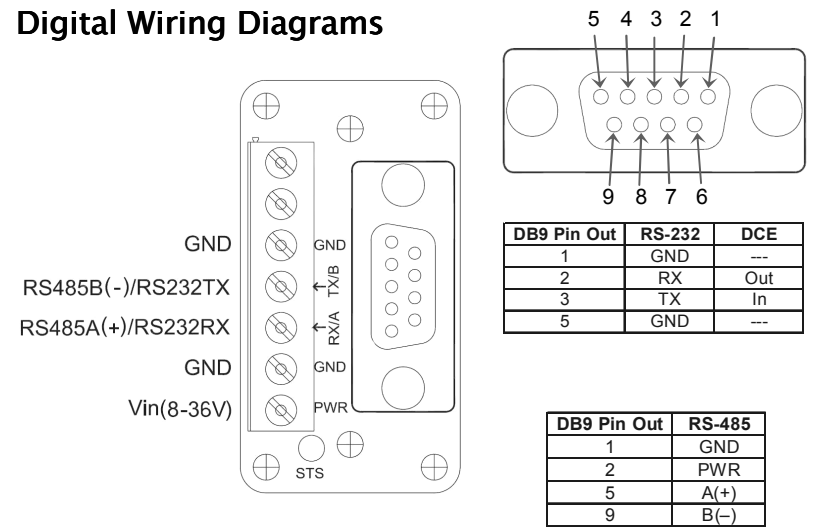

In 4-20mA two-wire mode, stay within the operating area of the load curve for load resistance and loop voltage to assure proper performance and maintain accuracy.

	mount, externally powered	multi-drop networks
ZA900447-00052	DB-9 Cable, male x female – optional accessory	Option for RS-232 and RS-485 support
Z9R111	Meriam Serial Protocol Implementation Guide	On CD and available at www.meriam.com

Mounting Options

M1500 mounting options include panel and DIN rail mount. Both are standard on all models and hardware is included with shipment.

Panel mounting is achieved using the cut out and mounting hole guides below. Plan the mounting hole locations so the P1 (HI) and P2 (LO) ports will be in the desired position upon completion. The four Port Manifold template is only used for M1500-DIxxxx models with optional flushing ports.

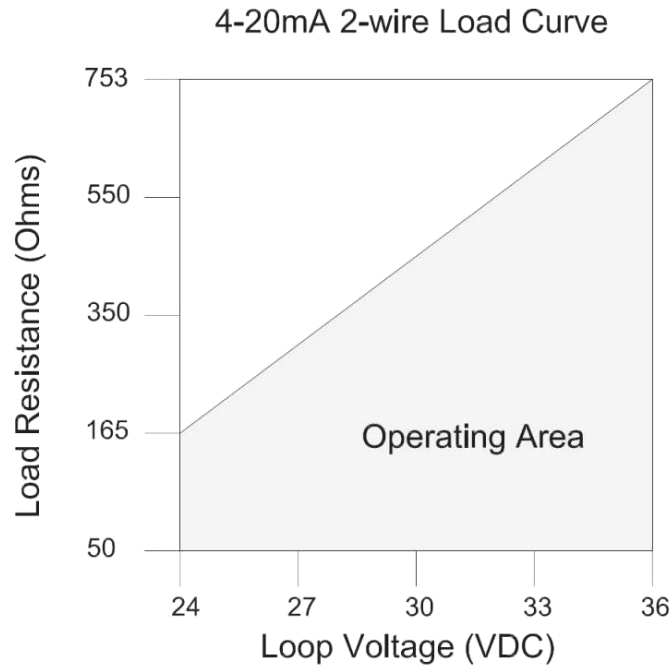

Max Load Resistance = 753 Ohms (at 36 VDC)

Min Load Resistance = 50 Ohms

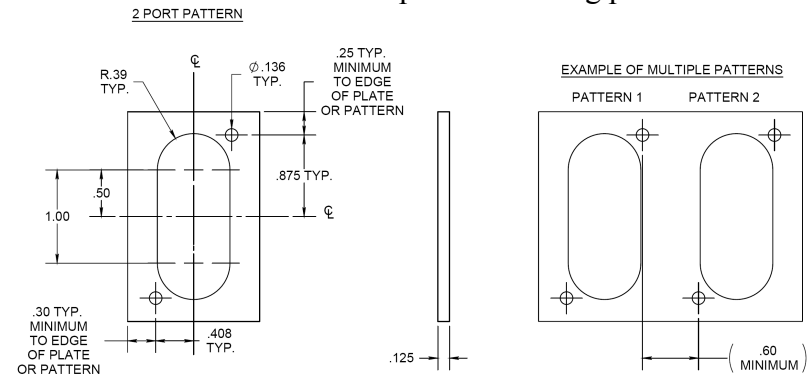

Panel Mounting Template for 2 Port Manifold

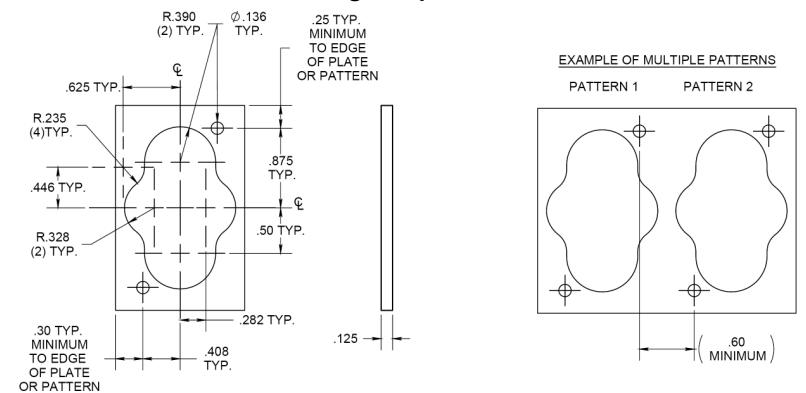

Panel Mounting Template for 4 Port Manifold (M1500-DIxxxx with optional flushing ports)

Once the panel cut out is made and the mounting holes are drilled, remove the corresponding set of diagonal screws from the M1500 pressure manifold. Insert the M1500's pressure manifold through the rear of the panel cut out. Locate the longer panel mounting screws supplied with the M1500, install them through the panel holes, and thread them into the vacated holes in M1500 pressure manifold. Tighten as needed. A completed panel mount is shown below.

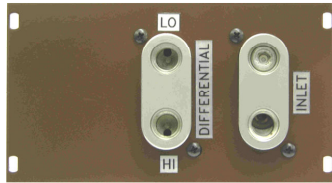

NOTICE The factory installed DIN rail clip may be removed from the M1500 enclosure if desired for panel installation. Use a Phillips head screw driver to remove the mounting screw and clip. Reinstall the screw to prevent debris from entering the enclosure.



DIN rail mounting is accomplished using the factory-installed DIN clip located on the edge of the M1500 enclosure. DIN rail mounting is excellent for mounting several M1500s in close proximity to one another, either inside a protective enclosure, or on a convenient mounting surface or wall. For high vibration applications use the longer panel mount screw to secure enclosure to DIN rail.

Pressure Connections

WARNING Failure to keep pressure below specified limits could result in death or serious injury. See

4-wire 4-20mA with Switches, con't

1. For 4-wire commissioning always connect external supply to PWR and GND terminals before connecting isolated loop supply to LP+ and LP-.
2. Isolated power supply is required for LP+ / LP- loop.
3. Do not short LP- and GND terminals.
4. Switches are solid state, opto-couplers with SPST operation (Clare model CPC1008N). Switch circuits are isolated from each other and from the M1500 mA output.

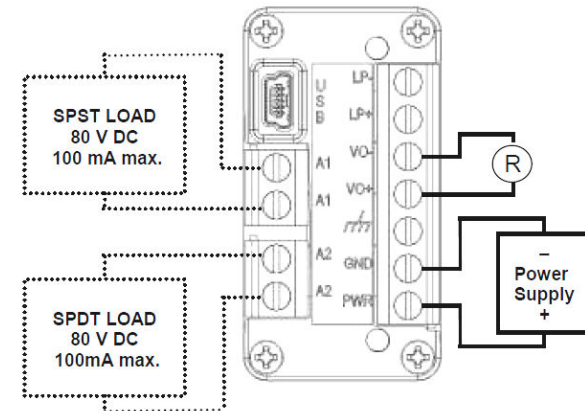

4-wire 0-5 V DC with Optional Switches

24 VDC nominal – see "Power Requirements" in the Specifications section of this manual for more detail
 Note: Switches are solid state, opto-couplers with SPST operation (Clare model CPC1008N). Switch circuits are isolated from each other and from the M1500 mA output.

Wiring Diagrams

Analog Wiring Diagrams

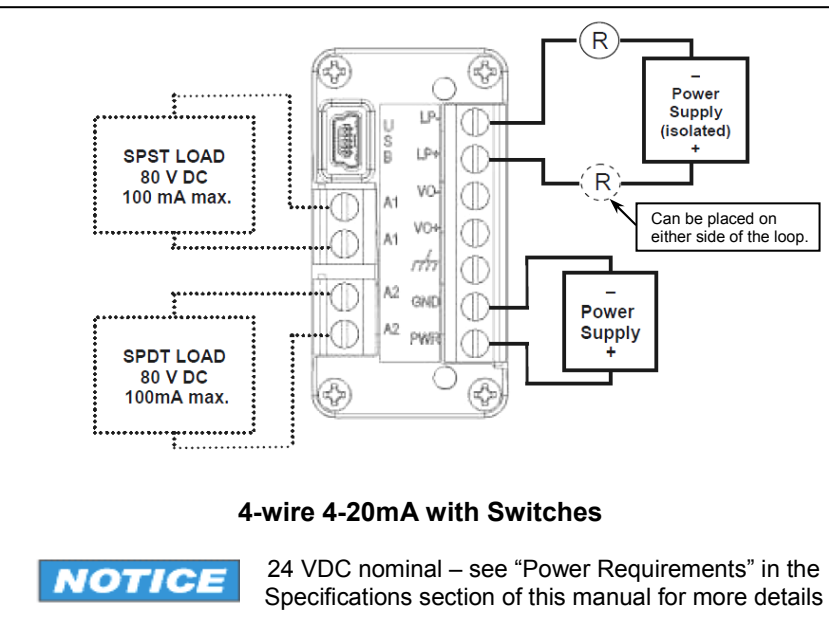
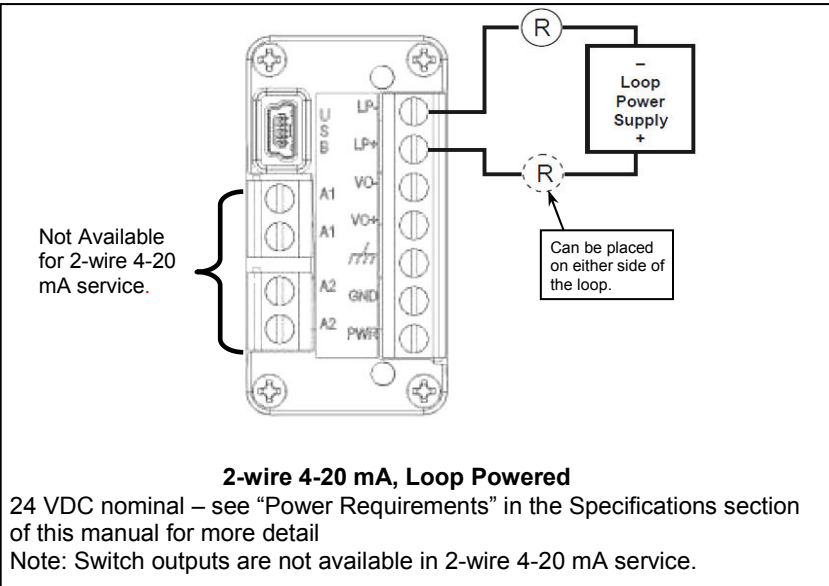

section – Specifications of this manual.

NOTICE All pressure connections are 1/8" NPT (female). A wrench should be used on the flats of the pressure manifold to hold it securely and prevent accidental damage when installing or removing a pressure fitting. Use suitable thread tape or thread sealing compound for leak-free connections.

NOTICE 3-valve equalizing manifolds are recommended for differential pressure units to prevent accidental damage while installing or commissioning M1500-DN and -DI transmitters and to support zeroing procedures. See the Specifications section of this manual for pressure limit information on differential and other pressure types. See the Zeroing section for information on zeroing the M1500.

Single Pressure Sensor Models

Single pressure sensors are available in all M1500 pressure and output types.

Differential pressure types, DN and DI models, have two pressure ports in the 316L SS manifold. The ports are engraved **P1** (HI connection) and **P2** (LO connection). Connect the application high pressure to the **P1** port and the low pressure to the **P2** port for differential applications. For Vacuum applications using differential models, vent the **P1** port to atmosphere and connect the vacuum line to the **P2** port. Note that the output of the M1500 in this vacuum configuration will transmit “positive” values. The receiving device will need to be configured to add the negative sign (-) to the received value.

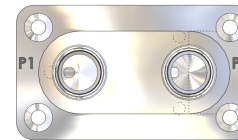

DN & DI Standard Manifold
P1 = HI, P2 = LO

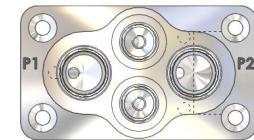

DI Optional Flushing Manifold
P1 = HI, P2 = LO

DI models are available with optional flushing ports to allow flushing the manifold interior (see graphic at right above). This is desirable for dirty liquids, liquids with particulates or suspended solids, or congealing liquids. Use solvents compatible with 316SS and Viton only.

WARNING

Spray hazard. Wear approved safety glasses and impermeable gloves. DO NOT pressurize the system; failure to follow these instructions could result in death or serious injury.



The flushing ports, an available option on DI models, are linked by internal passages to their respective P1 or P2 port. If a cleaning solvent is injected into one port it will flow through the manifold and the solvent will exit from the connected port. DO NOT pressurize the cleaning solvent as spray or stream flow could occur. Meriam recommends using a solution recovery system to capture the used cleaning solution. See the Specification section of this manual for fitting details and wetted parts material. Refer to the solvent manufacturer's Material Safety Data Sheet for safe handling information.

Gauge, Compound and Absolute pressure types in single sensor M1500 Digital Transmitters use the pressure port marked P1 on the manifold. Gauge pressure measurements are referenced to atmospheric pressure inside the enclosure and measure from 0 to the full scale range. Compound units are gauge units that measure down to full vacuum (approximately -14.7 PSIG) as well as up to the positive full scale range. Absolute pressure measurements are internally referenced to a complete vacuum on the P2 side of the pressure sensor. See drawing below.

NOTICE

A second pressure port is present on single sensor models but has been factory sealed with an appropriate venting plug. Do not remove the plug for any reason. GI, CI, and AI units cannot be converted to other pressure types in the field. See drawing below.

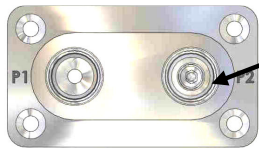

Permanent plug.
Do Not Remove

GI, CI and AI Manifold

Dual Pressure Sensor Models

Dual pressure sensors are available for digital communication models only. Any combination of GI, CI or AI sensors can be accommodated.

Zeroing Digital M1500s (non-Absolute models)

A pressure zero or factory zero command is used to zero digital M1500's using MSP (see the MSP Implementation Guide on the product CD) or LabVIEW commands. Be sure to vent all M1500 pressure connections to atmosphere and wait several seconds for stabilization before sending zero command.

Zeroing For Mounting Position

NOTICE

Meriam recommends zeroing the M1500 in its final mounting position to null any orientation effects caused by fill fluid in DI, GI, CI or AI models or by protective silicon gel in the case of DN models. Effects are relatively small for all but DI models. DI models are sensitive about the roll axis but when mounted in the final position and zeroed, DI models are very stable and accurate to the specification listed in this manual.

Zeroing DI Models For Static Pressure Effect

NOTICE

M1500-DI models are available in measurement ranges from 1 to 500 PSID for common mode static pressures up to 1000 PSID. The zero reading on these units is offset in a uniform way by the static pressure of the service. The offset is easily zeroed out using the M1500 zeroing command. Meriam recommends applying normal static pressure to the subject M1500-DI using a 3-valve equalizing manifold. The M1500-DI should be zeroed under normal static pressure conditions with the equalizing valve open.

Zeroing the M1500

Meriam recommends zeroing the M1500 prior to use for DN, DI, GI and CI models and periodically thereafter as needed. AI models normally do not need to be zeroed prior to initial use. Two types of zeroing are supported:

1. Pressure Zero: This recommended method takes a “snapshot” of the measured pressure when the M1500 is vented to atmosphere for DN, DI, GI and CI models or, in the case of AI models, when a vacuum of less than 100 microns absolute is applied.

NOTICE M1500 DN, DI, GI and CI models can be zeroed only when the newly applied zero is within $\pm 5\%$ FS. This prevents accidentally zeroing at relatively high offset pressures. If outside the $\pm 5\%$ FS limit, an error message is given and the manometer does not zero. The AI model limit is 100 microns absolute.

2. Factory Zero: This method restores the calibration curve to the original zero taken at the factory.

NOTICE The Factory Zero feature is intended for comparison purposes only. Factory Zero should not be used as a reference for actual pressure measurement because zero-drift occurring after shipment from the factory would not be accounted for.

Zeroing Analog M1500s: non-Absolute models

Use the Meriam Setup Utility to zero analog versions of the M1500. Follow the “PC / M1500 Interface - For Analog Configuration” section of this manual to connect the M1500 to a host PC. Open the Meriam Setup Utility, set the appropriate Com Port and click on the Measure / Configure button. Vent all M1500 pressure connections to atmosphere and wait several seconds for stabilization. Then click the Zero button on the software. To access the Factory Zero control, click on the Field Re-Calibration button on the opening page of the software.

Zeroing Analog M1500s: Absolute Pressure Models

M1500-AI models are re-zeroed using the Meriam Setup Utility. Reset to Factory Zero using the appropriate controls in the Meriam Setup Utility. To take a new pressure zero, apply a vacuum of less than 100 microns absolute. Then select the Zero button from the Utility.

Dual pressure models use the P1 port for pressure sensor 1 and the P2 port for pressure sensor 2. See the example below.

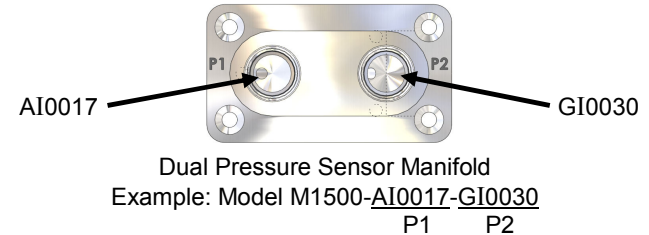

Installation and Operation

M1500 Digital Communication Models

Digital communication delivers the best possible accuracy to compatible receiving devices. M1500 models are available with RS-232, RS-485 and USB. PC configuration software is included with shipment to support set up of engineering unit, damp rate and other parameters and functions. Send / receive functions are supported by MSP, a DLL and LabVIEW® VIs. To program your system using these protocols, see the resources available on the product CD ROM and at www.meriam.com under “Resources / Application Notes”.

The M1500 pressure default network address is 40 (0x28 Hex) and module address is 64 (0x40 Hex) for MSP and LabVIEW® USB units have communication port addresses assigned by the host PC.

Digital M1502 models have two pressure sensors in one enclosure. The sensors can be any combination of GI, CI or AI types. A single command from MSP returns both pressure signals from the M1502.

RS-232

RS-232 is used for point-to-point communication. The M1500 is powered through the terminal block and uses a DB-9 (female) connector or terminal block for digital communication. Terminal labels follow RS-232 standard TIA/EIA-232. See the Wiring Diagrams section for details.

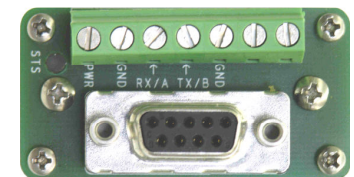

RS-232 / RS-485 Connector

RS-485

RS-485 communication is best for multipoint networks. The M1500 can be powered and communicated with using either the terminal block or the DB-9 pin outs for half-duplex communication. See the Wiring Diagrams section for details.

USB

High power USB ports supply power for this M1500 version and can be used for point-to-point interface with a PC port or for multiple interfaces using externally powered USB hubs. The M1500 uses a standard USB type B connector.

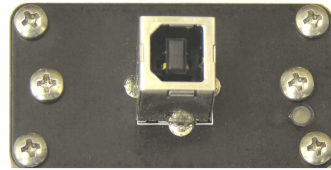

USB Connector

USB drivers for the M1500 must be installed on the host PC prior to communication. these drivers are on the product CD ROM.

NOTICE M1500 with USB will not work using low power USB ports; examples are keyboard USB and unpowered USB hubs. Use the M1500 with high power (500 mA) USB ports only and powered USB hubs only.

(3.5 PSI) at which point it will close. As the pressure continues to decrease the switch will remain closed until the pressure reaches the Lower Value setpoint minus the Reset Deadband ($0.4 - 0.075 = 0.325$ PSI) at which point it will open.

2. Digital Output 2 is set up as shown in Meriam Setup Utility.
Output action = Open
Comparison type = Greater Than
Value = 0.4000 PSI
Reset Deadband = 0.0750 PSI

As the pressure increases from 0 PSI the switch will remain closed until the pressure reaches the Value setpoint (0.4 PSI) at which point it will open. As the pressure continues to rise the switch will continue to remain open since the comparison says the pressure must be Greater Than the Value setpoint for the output action to occur.

Now the pressure begins to decrease. The switch will remain open until the pressure reaches the Value setpoint minus the Reset Deadband ($0.4 - 0.075 = 0.325$ PSI) at which point it will close.

The Transmitter Alarm groupbox contains a selection button for enabling or disabling an alarm when the pressure sensor has reached its hard over/under range limits. This occurs when the sensor can no longer compute a pressure measurement. When enabled and an alarm is detected, the output will go to 22.5mA when in current mode. In voltage mode, the output will go to 5.1V when the alarm condition is detected.

The Digital Output groupboxes allow the user to configure the parameters associated with Digital Output 1 & 2. These include the Output action (Closed, Open or Inactive), Value setpoint(s), Comparison type (Between, Greater Than, etc...) and Reset Deadband. The Value setpoint(s) and comparison type work together to establish the trigger points for the digital outputs. The Reset Deadband determines the amount of hysteresis around the Value setpoint(s) to eliminate continuous toggling of the digital outputs at the trigger points. The minimum Reset Deadband is 0.5% of the sensor limit range (USL - LSL). If there are two setpoints, the maximum Reset Deadband is half of difference between them (Upper Value – Lower Value).

Notes:

The user parameters (pressure) are entered in engineering units of the measurement module.

All user parameters entered are validated by the Meriam Setup Utility.

Examples:

1. Digital Output 1 is set up as shown in Meriam Setup Utility.
Output action = Closed
Comparison type = Between
Lower Value = 0.4000 PSI
Upper Value = 3.5000 PSI
Reset Deadband = 0.0750 PSI

As the pressure increases from 0 PSI the switch will remain open until the pressure reaches the Lower Value setpoint (0.4 PSI) at which point it will close. As the pressure continues to rise the switch will remain closed until the pressure reaches the Upper Value setpoint plus the Reset Deadband (3.5 + 0.075 = 3.575 PSI) at which point it will open.

Now the pressure begins to decrease. The switch will remain open until the pressure reaches the Upper Value setpoint

M1500 Analog Models

Analog units are set up in the field using the supplied M1500 Meriam Setup Utility and a USB type A to USB type mini-B cable. Power is provide over the USB cable for setup operations. The LED on the base of the transmitter will blink red when only the USB cable is connected. The Meriam Setup Utility software supports pressure zero, configuration of the output type and output span, plus selection of engineering units, damp rate and other parameters (see the Firmware Features section of this manual for more details). Load the software on a suitable PC and use optional p/n Z9P273 USB cable to connect the PC to the M1500's USB port. Set up the transmitter as desired using the Meriam Setup Utility.

Current Output

The M1500's 4-20 milliAmpere (mA) output can be used with 2-wire loop power or in a 4-wire configuration. 2-wire power supplies should be 24-36 VDC (60 mA minimum). The 4-wire loop power supply should be an isolated type (floating ground), 20-36 VDC (60 mA minimum) and the external supply should be 12-36 VDC (60 mA minimum). Minimum loop impedance is 50Ω. See the Wiring Diagrams section and connect as appropriate.

The NAMUR low/high saturation limits for 2-wire and 4-wire current mode is 20.5mA.

The 20mA value can be set over a 4:1 turndown of the transmitters URL.

NOTICE For 4- wire commissioning always connect the external supply to the PWR and GND terminals before connecting the isolated loop supply to LP+ and LP-.

Voltage Output

Voltage output is 0-5 V DC but can be configured using the Meriam Setup Utility for any output span (for example, a 1-5V span may be more convenient for some applications). The voltage output uses a 4-wire system and requires a 12-36 VDC (60 mA minimum) power supply. The M1500 will draw a maximum of 10 mA from the power supply. See the Wiring Diagrams section for details. The M1500 Transmitter can drive an

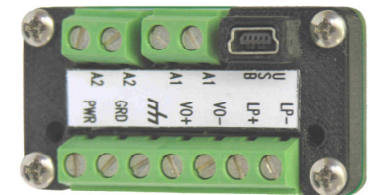

Analog Connector

output load having an impedance of 10K ohms or more in parallel with up to 1 μ F of capacitance.

The low/high saturation limits for voltage mode are 0.0V and 5.1V respectively.

The 5V DC value can be set over a 4:1 turndown of the transmitters URL.

Switch Output

Two solid state, opto-coupler, polarity independent, SPST switches are included on Analog output models of the M1500. The opto-couplers are low power, rated for 80V DC and 100 mA max. Their use is limited to 4-wire 4–20 mA or 4-wire 0–5 VDC options only (not available for 2-wire 4–20 mA operation).

Wiring Detection Feature

The M1500 has a wiring detection feature that is active for the first five (5) minutes after power up. Complete the output wiring within the 5 minute period for proper operation. If wiring is not completed in the allotted time, simply cycle power to re-activate the wiring detection sequence.

- 2-wire 4-20mA wiring → 2 green LED blinks
- 4-wire 0-5Voltage wiring → 3 green LED blinks
- 4-wire 4-20mA wiring → 4 green LED blinks

If a fault condition occurs after the initial 5 minute period (e.g. output wiring changed, voltage drops below minimum or climbs above maximum specified value), the green LED blink sequence will change to a red sequence.

Configuration Using Meriam Setup Utility

The Meriam Setup Utility application is used to configure the analog output as well as the digital outputs of the M1500. The image below is the analog setup dialog box from the program.

Analog Setup Screen from Meriam Setup Utility

The Pressure groupbox displays the upper and lower sensor limits (LSL/USL), current pressure reading, upper and lower range values (LRV/URV), minimum span for the range and a Zero button. The sensor limits are fixed values which are factory set. The sensor range values are user configurable parameters which must meet the minimum span requirement. The minimum span is specified as 25% of the sensor limit delta. In addition, URV must be greater than LRV. The zero button allows the user the zero the sensor at the current pressure measurement.

The Output groupbox contains the output type and range selections. The Volts and Current radio buttons allow the user to select the output type. The AO@LRV and AO@URV edit fields scale the voltage or current output signal to the pressure input range.